



PROJECT

TYPE

DATE

ITEM NO.

NOTE

## BACKLIT LED FLAT PANEL

## BFPL-HB Series

Panels and Troffers

### DESCRIPTION

The Alphalite Backlit LED Flat Panel combines the benefits of long life, controllability, and energy savings with elegant design and superior quality of light. The BFPL luminaires optimize LED optics and electronics to deliver energy savings and high performance.

### APPLICATION

Indoor general/ambient illumination. Idea for offices, schools, retail, and other architectural spaces that demand energy reduction and high quality light.

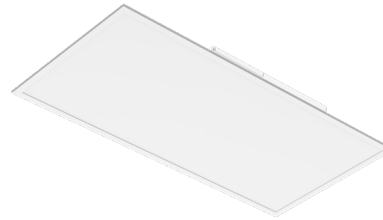

### SPECIFICATION FEATURES

#### Construction

Rugged construction: solid high quality steel housing and aluminum frame with great heat dissipation and low light degradation. Rated as vibration and impact resistance. Housing and optics maintain damp location rating with all internal components.

#### Electrical

Luminaire utilizes long life, high efficacy LEDs and a highly efficient, reliable and flicker-free ( $\leq 10\%$ ) LED driver. 120-277V comes standard and 120-347V as option input voltage for increased versatility. 1-10V continuous dimming comes standard, ideal when used in conjunction with controls and sensors and supports dim to off.

#### Mounting

Installs recessed with T-bar grid.

#### Optics

Frosted polystyrene diffuser, uniformity light achieved by delivering a comfortable mix of light to working and surrounding surfaces, creating balanced illumination throughout the environment. Occupants can realize a productive and comfortable atmosphere through enhanced light quality and distribution.

#### Certifications / Regulatory

cULus listed for dry and damp locations rated, IC rated, FCC Part 15 Class B, DLC Premium listed in Luminaires for Ambient Lighting of Interior Commercial Spaces and Low Bay category.

#### Warranty

7-year limited warranty. See complete warranty terms for details.

### Quick Ship Product

BFPL-24(50/40/30HB)/8A

BFPL-22(40/30/20HB)/8A

BFPL-14(40/30/20HB)/8A

## ORDERING INFORMATION

Sample Number: BFPL-14(40/30/20HB)/8A

Series	Length	Lumen Package			CRI
<b>BFPL</b>	<b>14</b> - 1'x4'	<b>1'x4'</b>	<b>2'x2'</b>	<b>2'x4'</b>	<b>8</b> - 80CRI
- Backlit LED	<b>22</b> - 2'x2'	<b>14(40/30/20HB)</b>	<b>22(40/30/20HB)</b>	<b>24(50/40/30HB)</b>	
Flat Panel	<b>24</b> - 2'x4'	- 40/30/20W, 5200/3900/2600lm	- 40/30/20W, 5200/3900/2600lm	- 50/40/30W, 6500/5200/3900lm	

CCT	Auxiliary Power	Input Voltage	Control Option	Emergency Backup
<b>A</b> - Adjustable CCT (5000/4000/3500K)	<b>(Blank)</b> - without AUX <b>12V</b> - with AUX 12V *AUX 12V for PIR sensor	<b>(Blank)</b> - 120-277V <b>C</b> - 120-347V	<b>OS</b> - Occupancy PIR, daylight and daylight harvesting sensor *Easy to install in field (Sensor spec sheet refer to MMS-DCI06R) Configuration tool required (RC-RM51 order separately) Daylight and daylight harvesting disabled by default	<b>EM8W</b> - 8W constant power with integrated self-diagnostic test, with LECP flat test switch <b>EM15W</b> - 15W constant power with integrated self-diagnostic test, with LECP flat test switch

Assembly in USA	Accessories
<b>(Blank)</b> - TAA Compliant <b>BAA</b> - Assembly in USA	<b>BFPL-SACC</b> - Suspension mount kit <b>FLK-xx</b> - Flange Kit for drywall, xx as 14, 22 or 24 <b>BFPL-SMK-xxS</b> - Surface mount kit, xx as 14, 22 or 24

SUMMARY

Input Voltage	120-277V
Input Power	See energy data for details
Power Factor	>0.9
THD (Max.)	20%
Efficacy	130 LPW
Delivered Lumens	See energy data for details
Controls/ Dimming	1-10V dimming standard
Dimming Range	10-100%
CRI	>80
CCT	3500/4000/5000K Selectable
Operating Temp.	-4 °F ~ 113 °F (-20 °C ~ +45 °C)
Rated Life	70,000 hours

ENERGY PERFORMANCE DATA

Form Factor	Part No.	Rated Wattage (W)	Delivered Lumens (lm)	Efficacy (lm/W)
1'x4'	BFPL-14(40/30/20HB)/8A	40/30/20	5200/3900/2600	130
2'x2'	BFPL-22(40/30/20HB)/8A	40/30/20	5200/3900/2600	
2'x4'	BFPL-24(50/40/30HB)/8A	50/40/30	6500/5200/3900	

OPTICS

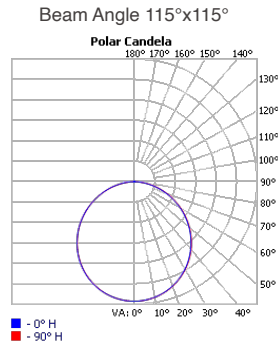

With Aux12V version supports install sensor



PHYSICAL PARAMETERS

DIMENSION

BFPL-14

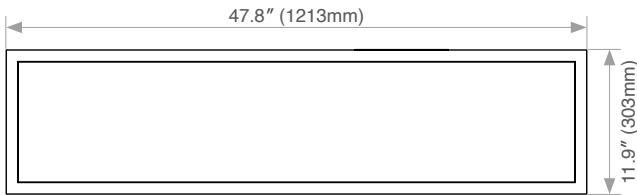

BFPL-22

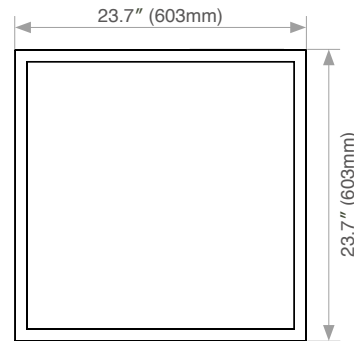

BFPL-24

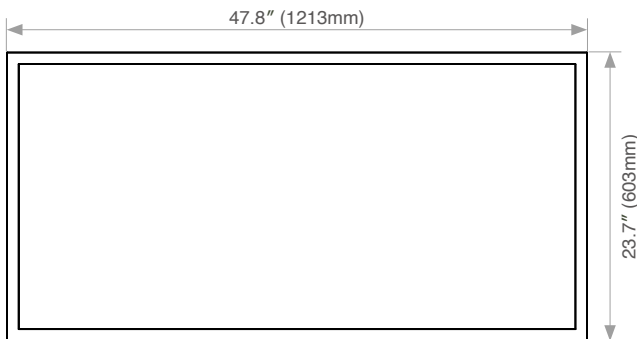

1.4" (36mm)

