



PROJECT

TYPE

DATE

ITEM NO.

NOTE

## LED OUTDOOR SURFACE CANOPY

## SCL Series

Canopy and Parking Garage  
Luminaires

### DESCRIPTION

The LED Outdoor Surface Canopy is a modern and versatile integrated LED solution that delivers long life and energy savings within a low profile design. The rugged housing and dedicated LED design offers advanced thermal management and protection against outdoor and semi-outdoor environments.

### APPLICATION

The SCL solution is ideal for walkways, parking structures, drive-thrus, cold storage, garages, outdoor aisles, and walk in coolers.



### SPECIFICATION FEATURES

#### Construction

Rugged die-cast aluminum housing withstands outdoor environments. Outer surface treated with durable powder coating to provide resistance to corrosion, rust, weathering, and UV degradation. Performance-engineered, integral heat dissipation fins provides superior thermal management for long life and reliability.

#### Electrical

Luminaire utilizes long life, high efficacy LEDs and a highly efficient, reliable LED driver. 120-277V input voltage for increased versatility. Comes equipped with quick disconnect for compliance with US code.

#### Mounting

Luminaire mounting designed for standard J-Box. Can be mounted directly to surface. Convenient and easy installation with universal mounting plate.

#### Optics

Precision-molded lenses provide various photometric distributions depending on application. LED lenses optimize performance and increase delivered light to desired areas. Light distribution Type VS.

#### Finish

Outer surface treated with durable powder coating to provide resistance to corrosion, rust, weathering, and UV degradation.

#### Certifications / Regulatory

UL listed for Wet location rated.

#### Warranty

5-year limited warranty. See complete warranty terms for details.

### Quick Ship Product

SCL-L40/40K  
SCL-60/50K

## ORDERING INFORMATION

Sample Number: SCL-L(40)/40K

Series	Lumen Package				CCT	Driver Option	Finish Color
<b>SCL</b>	<b>L(40)</b>	<b>60</b>	<b>H(85)</b>	<b>120</b>	<b>40</b> - 4000K	<b>(Blank)</b> - Without dimming	<b>(Blank)</b> - Dark Bronze
- LED Outdoor Surface Canopy	- 40W, 4640lm	- 60W, 6600lm	- 85W, 9860lm	- 120W, 12000lm	<b>50</b> - 5000K	<b>10V</b> - 0-10V continuous dimming	<b>WT</b> - White

#### Control Option

**OS** - Step dimming PIR Sensor and daylight sensor  
\*configuration tool required

#### Accessories

**SCL-PMK3/4** - Pendant mount adapter for 3/4" stem  
(stem not included)

SUMMARY

Input Voltage	120-277V
Input Frequency	50/60 Hz
Input Power	See energy data for details
Power Factor	> 0.95
THD (Max.)	20%
Efficacy	> 100 LPW
Delivered Lumens	See energy data for details
Controls/Dimming	0-10V dimming option available.
CRI	> 70
CCT	4000/5000K
Operating Temp.	-40°F ~ 122°F (-40°C ~ +50°C)

ENERGY PERFORMANCE DATA

Part No.	Rated Wattage (W)	Delivered Lumens (lm)	Efficacy (lm/W)
SCL-L(40)/40K	40	4640	116
SCL-60/50K	60	6600	120
SCL-H(85)/50K	85	9860	116
SCL-120/40K	120	12000	100
SCL-120/50K	120	12000	100

\*The delivered lumens above are based on highest wattage and 4000K.

OPTICS

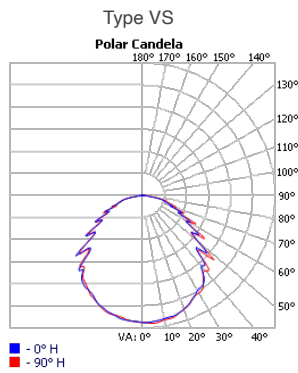

PHYSICAL PARAMETERS

DIMENSION

SCL-40, and 60

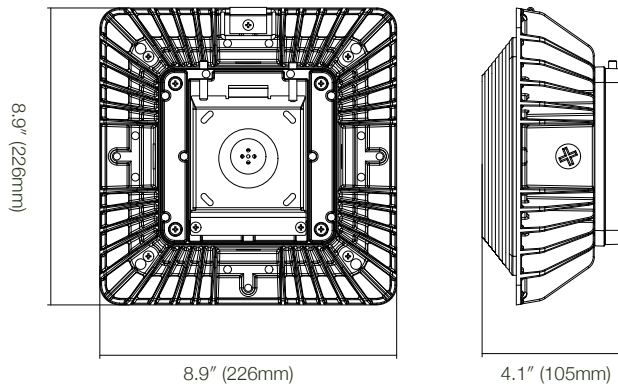

SCL-85, and 120

