

Installation Instructions

Die-Cast LED High Bay

HBDM Series



WARNING Risk of Fire and Electric Shock.

The luminaire must be installed by a qualified electrician in accordance with applicable federal, state, and local laws and codes. Installation requires knowledge of luminaire electrical systems and installer should be familiar with the operation of this product. If not qualified, do not attempt installation; contact a qualified electrician. Manufacturer assumes no responsibility for the improper installation of this luminaire. When installing the fixture, drilling may damage luminaire wiring and electrical parts. Check for wiring and components in enclosure before drilling. Turn OFF power before installation or attempting any maintenance.

To prevent wiring damage or abrasion, do not expose wiring to edges of sheet metal or other sharp objects. When installing this kit, drilling may damage luminaire wiring and electrical parts. Check for wiring and components in enclosure before drilling.



WARNING Risk of Burn.

Disconnect power and allow fixture to cool before handling or servicing.



WARNING Risk of Personal Injury.

Wear gloves or proper handling protection to prevent cuts or abrasions when handling and maintaining this product. This equipment may have sharp edges. To reduce the risk of death, personal injury or property damage from fire, electric shock, falling parts, cuts/abrasions, and other hazards read all warning and instructions included with and on the fixture box and all fixture labels.

Avoid direct eye exposure to the light source while it is on.

NOTICE

- Green ground screw provided in proper location. Do not relocate.
- Minimum 90°C supply conductors.
- Suitable for Dry or Damp location.
- Specifications and dimensions subject to change without notice.



Contact manufacturer with any questions or concerns regarding installation of this luminaire.

Alphalite

Installation Instructions

Die-Cast LED High Bay

A: CCT & Wattage Adjustment

You can change the CCT 5000/4000 and Wattages by the DIP switches, default factory setting is 5000K and highest wattage.

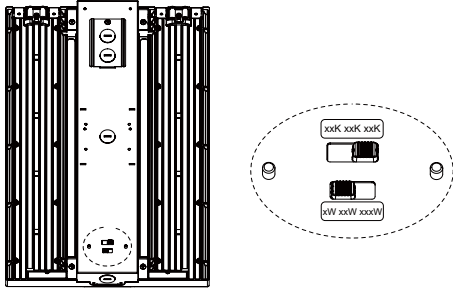

B: Mounting

Part list included

No.	Part Name	Qty	Picture
1	Fixture	1	
2	V shape Hook	2	
3	Chain (3.28ft)	2	
4	Instruction sheet	1	\

a) Suspension mount

- Secure chain around structure, insert chain on to V shape hook and insert hook into side of channel as shown. We offer the 3.28ft adjustable aircraft cable HB-ACC instead of chain (HB-ACC order separately)

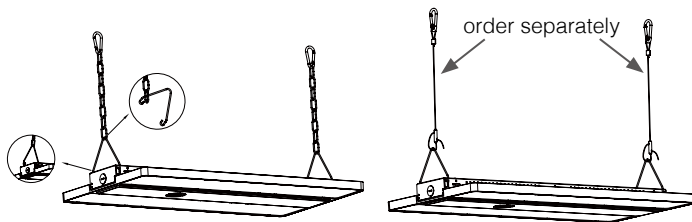

- Remove access plate and attach conduit to access plate. Make electrical connections according to wiring diagram. Reattach access plate to complete installation.

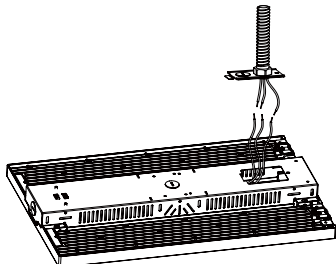

b) Pendant mount (HBDM-PMK order separately)

- Attach 3/4" NPT stem conduit (by others) to the HBDM-PMK bracket
- Secure bracket into fixture slots.
- Remove the knock-out and wiring with power cords.
- Lock both side brackets to cover the wires.

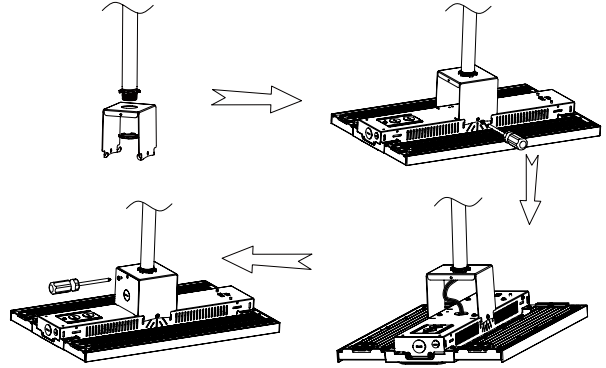

c) Surface mount (HBDM-SMK order separately)

- Mount the bracket on the rail or ceiling. (Screws provide by other, and the hole and distances as listed below)
- Assemble the fixture on the bracket and fix it with screws
- Remove the knock-out and wiring with power cords.

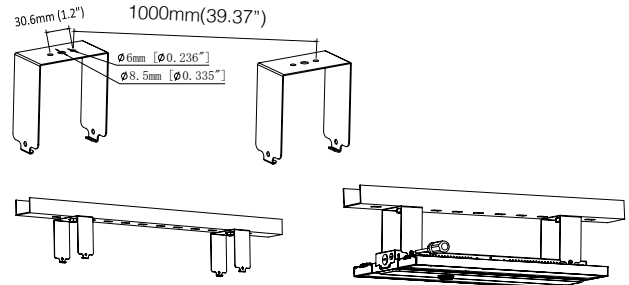

Alphalite

Installation Instructions

Die-Cast LED High Bay

C: Install Backup driver with different mounting

For suspension or surface mount only, not available for pendant mount. (EM, HBDC-EM-MK order separately)

1. Attached HBDC-EM-MK brackets on fixture and tighten it with 4 screws.
2. Take out the cover plate from fixture, and pass through the conduit to the knock-out and wiring with fixture as wiring diagram below.
3. Fix cover plate on site, and fix the EM to brackets.

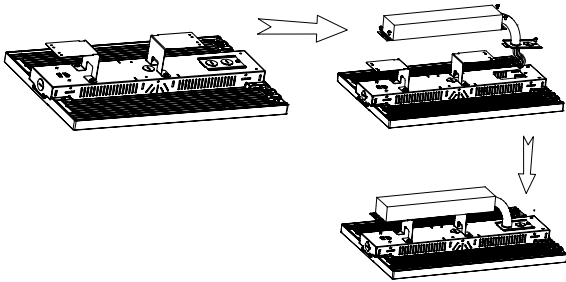

4. Install chain or aircraft cable for suspension mount or install HBDM-SMK for surface mount (Aircraft cable HB-ACC, surface mount kit HBDM-SMK order separately)

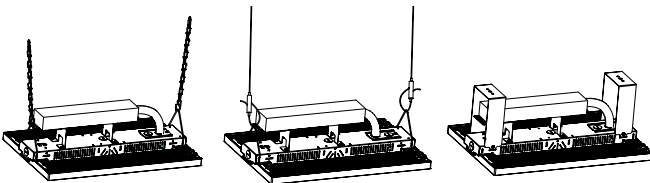

D: Install sensor at field

(PIR sensor MMS-DC-PIR4T, RC-100 ; or Bluetooth with PIR sensor MMS-PIR4T-BLE-SR. Order separately.)

1. Removed the cover by hand.
2. Twist-lock the DC sensor to the socket.
3. Be sure sensor is tighten before use, setting the data according to the spec sheet of sensor and remote controller RC-100; Bluetooth sensor control by modibe app)

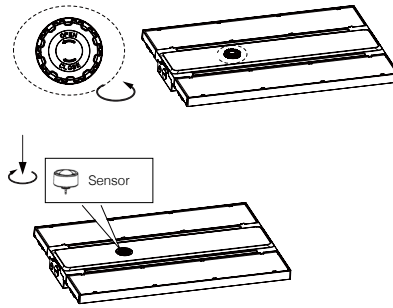

E: Install wire guard at field (HBDM-WG)

1. Place the wire guard on the fixture and fix it with screws.



HBDM EM installation Wiring Diagram:

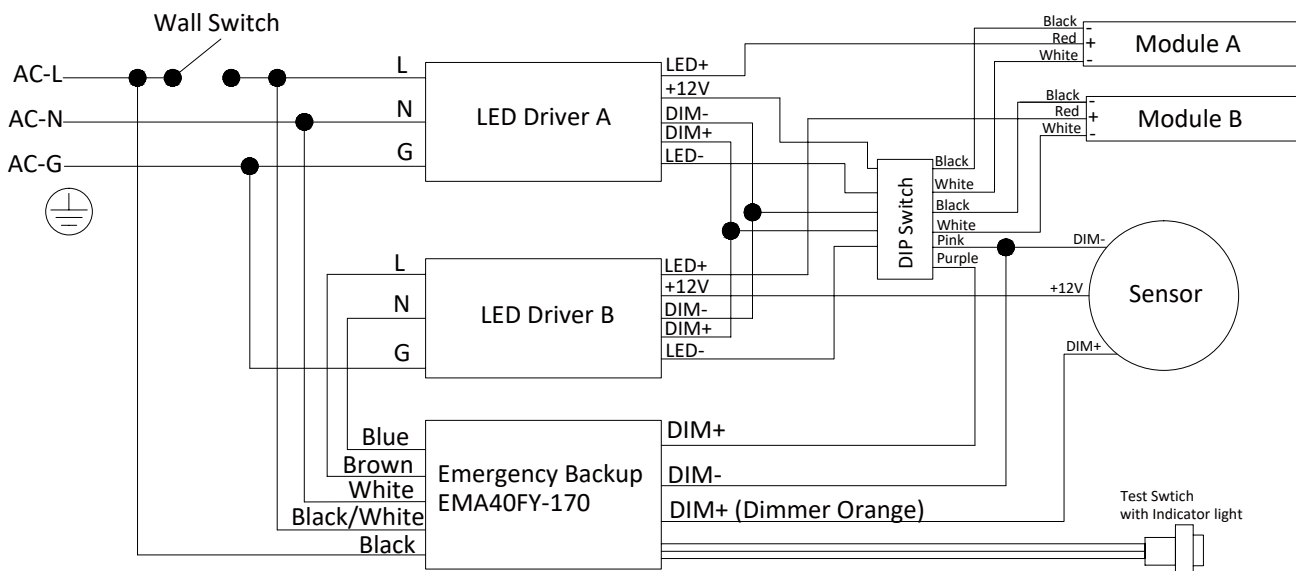

Alphalite